

# Duct Pressure Transducer

## Model PR-276

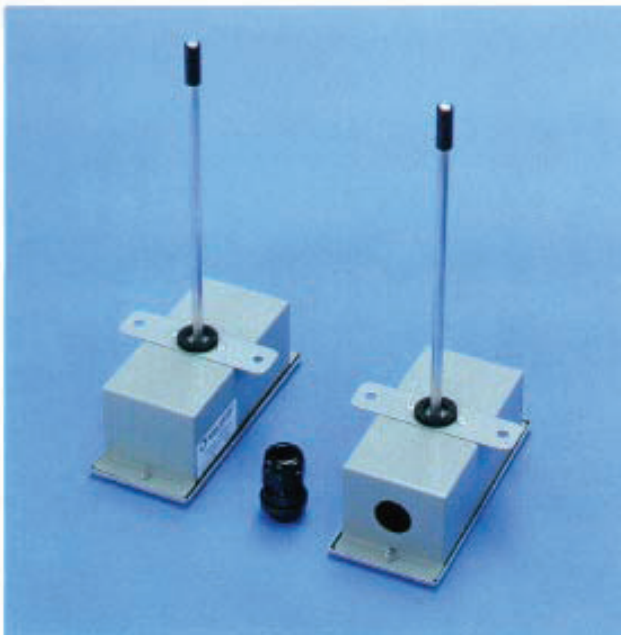

- 100% solid state, micro-machined, glass-on-silicon, ultra-stable capacitance sensor
- Duct pressure transducer and static pressure tip integrated as one unit
- Up to 10 PSID overpressure without zero shift
- Up to 3 field selectable ranges available in a single unit
- Wide 12-40 VDC/12-35 VAC unregulated supply voltage
- Two temperature compensated output versions, 4-20 mA 2-wire or field selectable 0-5 VDC/0-10 VDC
- NIST traceable calibration
- Rugged NEMA 4 (IP-65) enclosure with external mounting bracket
- Short circuit and reverse polarity protected
- Conforms to EMC standards EN50082-1/ EN55014/ EN60730-1

The PR-276 incorporates sophisticated integrated circuits and a new micro-machined glass-on-silicon (GI-Si) capacitance sensor to not only provide a high level, fully conditioned and temperature compensated output, but also to offer up to three (3) field selectable pressure ranges in one unit. The field selectable feature eliminates costly inefficiencies by providing a single unit which can be configured to cover all the pressure ranges for a particular application. For instance, 1.25", 2.50" and 5.00"wc in one unit. To substantially reduce installation cost and to eliminate costly control panels, the PR-276 incorporates a pressure sensor and a static pressure tip integrated as one assembly. Two industry standard output versions are available, 4-20mA 2-wire loop or field selectable 0-5 VDC/0-10 VDC. Wide 12-40 VDC or 12-35 VAC unregulated supply voltage and a broad 25°F-150°F compensated temperature range ensures compatibility to most of the applications. Rugged NEMA 4 (IP-65) enclosure, gasketed cover, external mounting bracket, fully temperature compensated NIST traceable accuracy, and a liberal two year warranty are some of the features which make the PR-276 not only the most reliable, but the lowest installed cost duct pressure transducer in the industry.

 **MAMAC SYSTEMS®**

8189 Century Boulevard • Minneapolis, MN 55317-8002 • USA  
800-843-5116 • 952-556-4900 • Fax 952-556-4997  
sales@mamacsys.com • www.mamacsys.com

Baird House, Units 6&7  
Pensnett Estate • Kingswinford  
West Midlands • DY6 7YA • United Kingdom  
01384-271113 • Fax 01384-271114

4 Armingier Court, Unit 2  
Holden Hill • S.A. 5088 • Australia  
08-8395-4333 • Fax 08-8395-4433

155 McIntosh Drive, Units 5&6 • Markham  
Ontario • L3R 0N6 • Canada  
905-474-9215 • Fax 905-474-0876

No. 22 Lorong 21A Geylang # 11-02  
Prosper Industrial Building  
Singapore • 388421  
656-3927273 • Fax 656-3927276

# PR-276

The PR-276 incorporates sophisticated integrated circuits to not only provide a high level, fully conditioned and temperature compensated output, but also to offer field selectable flexibility which was unheard of in the industry. The PR-276 offers up to three field selectable pressure ranges in one unit. In this way, a customer does not need to know the exact pressure range prior to selection. A unit can be field configured for the desired pressure range in the field. With fixed range units, in case of engineering error or incorrect selection, the only solution is expensive field recalibration or time consuming product exchange or replacement. Similarly, numerous units have to be kept in stock as spares to cover all ranges in case of field failure. The PR-276 with the field selectable pressure range feature, eliminates above mentioned costly inefficiencies. A single unit can be configured to cover all the pressure ranges in a particular application thereby eliminating any possibility of incorrect range selection. Additionally, one unit can be kept in stock and, in the event of a failure, it can be field configured thereby eliminating the need to stock numerous fixed range units. (For a complete listing of all the ranges available, please see the ordering information section on page three.)

To substantially reduce installation costs and to eliminate costly control panels, the PR-276 incorporates a pressure sensor and a static pressure tip integrated as one assembly. Instead of installing two devices, running a tubing from the static pressure probe to the pressure transducer and using up expensive space in the control panel, with the PR-276 one has to merely drill a 7/16" hole in the duct, insert the integral pressure tip, and use two sheet metal screws to complete the installation. The pressure tip has two precision orifices which are protected by baffles to significantly reduce any velocity pressure induced errors. The probe assembly is constructed out of extruded 6061T aluminum alloy. A gasket is provided on the bottom of the enclosure to seal against the duct.

On VDC output units, two additional field selectable options are available; dual outputs 0-5 or 0-10 VDC, and dual unregulated supply voltages 12-35 VAC or 12-40 VDC. By merely moving a shorting plug, one can select the desired output for the specific application. As far as supply voltage is concerned, the unit automatically configures for AC or DC and no field selection is necessary. Another feature is that the output is fully protected from short circuit to ground, or if the supply voltage is applied by mistake to the output. Past experience demonstrates that field related wiring problems do occur. Instead of denying this fact, this protection circuit is designed in to ensure trouble-free start-up. The VDC output unit is also designed to handle low impedance circuits. In fact, the unit can drive up to 1k ohm minimum. In this way, multiple controllers, indicators, or other devices can be paralleled to the output without performance degradation.

The mA output units can function over a wide unregulated supply voltage range: 12-40 VDC without any effect on calibration or performance. The unit has reverse polarity protection built in. As a result, it is next to impossible to damage the unit by mis-wiring. By using sophisticated low drop-out voltage regulators and CMOS integrated circuits, the mA output unit can drive very high output impedance. In fact, with only 12 VDC supply, the unit can drive 400 ohms. At 40 VDC, the unit is capable of handling up to 3000 ohms load. In this way, the output loop can be tied in series to multiple controllers, indicators, and other devices without degrading the performance.

Automated NIST traceable pressure controllers and precision Barocel pressure sensors are utilized to calibrate and certify the PR-276. Calibration data on each unit is archived digitally for SPC and QC purposes. All automated calibration systems are networked and data is available on-line to numerous individuals at the same time. In this way, extremely high standards of quality and calibration integrity are maintained. Each unit is individually temperature compensated in an environmental chamber. The temperature compensation data is also digitized and archived for future reference purposes. Compensating each unit individually ensures that published specifications are adhered to.

Due to the low mass of the micro-machined capacitance GI-Si sensor, the mounting orientation error is negligible. For extremely precise applications, if the unit is installed as indicated on the label, there should be no orientation error. However, due to space limitation, if the unit cannot be installed in the indicated position, the error can be easily removed by merely adjusting the zero trimmer. Since the zero and span trimmers are non-interactive, adjustment to the zero should under no circumstance affect the calibration integrity of the unit including linearity and repeatability specifications across the range.

The PR-276 incorporates a rugged NEMA 4 (IP-65) fully gasketed, dust proof and splash proof enclosure. The enclosure has an external mounting bracket to facilitate field installation. A 1/2" (.875"/22.25mm dia.) knock-out for conduit connection is also provided. A liquid tight cable connector is also supplied if the unit is not being hard wired. Once installed, the enclosure maintains its environmental rating and protects the electronics and the sensing element from condensation, corrosive contaminants and other environmental pollutants. The unit also has additional features for ease of installation including unpluggable terminal block, easily accessible zero and span trimmers, and conveniently located shorting plugs for field selection.

# PR-276

## Specifications:

**Accuracy\*:**  $\pm 1\%$  FS

**Overpressure:** 10 psid

**Supply Voltage:** 12-40 VDC  
12-35 VAC (VDC output units only)

**Supply Current:** VDC Units - 10 mA max.  
mA Units - 20 mA max.

**Enclosure:** 18 Ga C. R. Steel NEMA 4 (IP-65)  
6061T aluminum probe

**Finish:** Baked on enamel-PMS2GR88B

**Conformance:** EMC Standards EN50082-1(1992)  
EN55014(1993)/EN60730-1(1992)

*\*Includes non-linearity, hysteresis and non-repeatability*

**Compensated Temp Range:** 25°F-150°F (4°C-65°C)

**T. C. Error:**  $\pm 0.0125\%/^{\circ}\text{F}$  (.02%/°C)

**Operating Temp Range:** 0°F-175°F (-18°C-80°C)

**Media Compatibility:** Clean dry air or any inert gas

**Environmental:** 10-90%RH Non-Condensing

**Termination:** Unpluggable screw terminal block

**Wire Size:** 12 Ga max.

**Load Impedance:** 3K ohms max. at 40 VDC (mA output units) 1K ohms min. (VDC output units)

**Weight:** 1.0 lbs. (.45 kg)

## Ordering Information: PR-276-

	<b>RANGE</b>		<b>OUTPUT</b>
<b>R10</b> ("wc)	0 TO 5.0 / 0 TO 2.5 / 0 TO 1.25	<b>mA</b>	(4-20 mA 2-wire)
<b>R11</b> ("wc)	0 TO 15.0 / 0 TO 7.5 / 0 TO 3.75	<b>VDC</b>	(0-5 VDC or 0-10 VDC field selectable)
<b>R12</b> (pa)	0 TO 1250 / 0 TO 625 / 0 TO 312.5		
<b>R13</b> (pa)	0 TO 3750 / 0 TO 1875 / 0 TO 937.5		

**Example: PR-276-R10-mA:** With R10 Range which has three (3) field selectable range options and 4-20 mA output.

**CAUTION:** Do not use on oxygen service, in explosive/hazardous environment or with flammable/com-bustible media.

# PR-276

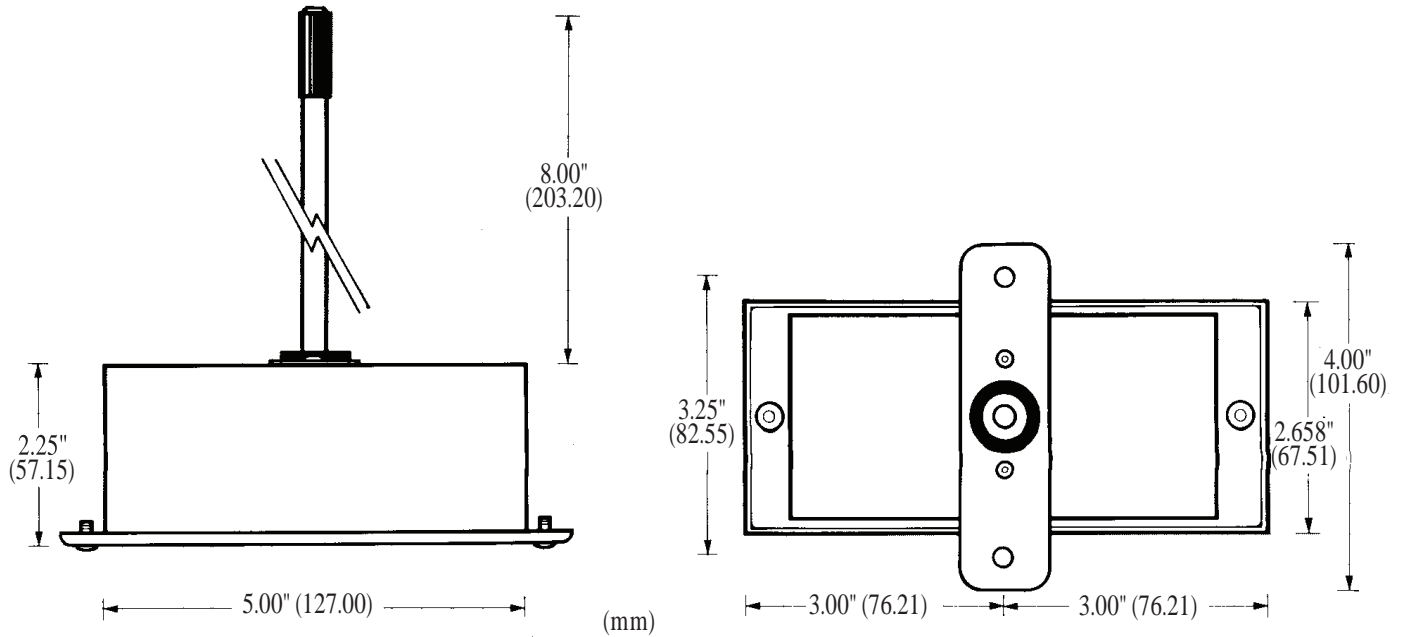

**WARRANTY:** MAMAC Systems, Inc. warrants its products to be free of defects in material and workmanship for a period of two (2) years from date of shipment. If a unit is malfunctioning, it must be returned to the factory for evaluation. A return authorization number (RMA) will be issued by the customer service department and this number must be written or prominently displayed on the shipping boxes and all related documents. The defective part should be shipped freight prepaid to the factory. Upon examination by MAMAC Systems, Inc., if the unit is found to be defective, it will be repaired or replaced at no charge to the customer. However, this warranty is void if the unit shows evidence of being tampered with, damaged during installation, misapplied, misused, or used in any other operating condition outside of the unit's published specifications.

**MAMAC Systems, Inc. makes no other warranties or representations of any kind whatsoever, expressed or implied, except that of title. All implied warranties including any warranty of merchantability and fitness for a particular purpose are hereby disclaimed. user is responsible to determine suitability for intended use.**

**LIMITATIONS OF LIABILITY:** The remedies of buyer set forth herein are exclusive and the total liability of MAMAC Systems, Inc. with respect to this order, whether based on contract, warranty, negligence, indemnification, strict liability or otherwise, shall not exceed the purchase price of the product upon which liability is based. **In no event shall MAMAC Systems, Inc. be liable for consequential, incidental or special damages.** MAMAC Systems, Inc. reserves the right to change any specifications without notice to improve performance, reliability, or function of our products.

Every precaution for accuracy has been taken in the preparation of this manual, however, MAMAC Systems, Inc. neither assumes responsibility for any omissions or errors that may appear nor assumes liability for any damages that result from the use of the product in accordance with the information contained in This manual.

## **MAMAC SYSTEMS®**

8189 Century Boulevard • Minneapolis, MN 55317-8002 • USA  
800-843-5116 • 952-556-4900 • Fax 952-556-4997  
sales@mamacsys.com • www.mamacsys.com

Baird House, Units 6&7  
Pensnett Estate • Kingswinford  
West Midlands • DY6 7YA • United Kingdom  
01384-271113 • Fax 01384-271114

4 Arminger Court, Unit 2  
Holden Hill • S.A. 5088 • Australia  
08-8395-4333 • Fax 08-8395-4433

155 McIntosh Drive, Units 5&6 • Markham  
Ontario • L3R 0N6 • Canada  
905-474-9215 • Fax 905-474-0876

No. 22 Lorong 21A Geylang # 11-02  
Prosper Industrial Building  
Singapore • 388421  
656-3927273 • Fax 656-3927276