



FE-1500 DUCT MOUNTED AIRFLOW MEASUREMENT STATION

DESCRIPTION

The **FE-1500** airflow measurement station consists of single or multiple airflow elements, factory mounted and pre-piped in a casing designed for flanged connection to the ductwork. Standard materials consist of a G90 galvanized casing and 6063-T5 anodized aluminum flow sensors, suitable for most HVAC applications.

The airflow averaging element, utilized in the FE-1500, is a head type device, which generates a differential (velocity) pressure signal similar to the orifice, venturi, and other head producing primary elements. The **FE-1500** is constructed so that strategically located sensing ports (based on duct size) continually sample the total and static pressures, when inserted normal to flow. The total pressures sensed by the upstream ports are continually averaged within the element in an isolated chamber. The static sensing ports (located where the influence of the velocity head is zero) are averaged in a second isolation chamber. Multiple elements are manifolded together for connection to a differential measurement device (gauge, transmitter, etc.) for flow measurement and indication purposes.

Features

- Low signal-to-noise ratio
- Multiple total and static pressure sensing ports along the length of the element
- Factory mounted and pre-piped in a flanged duct section (casing)
- $\pm 2\%$ accuracy throughout the velocity ranges of 100 fpm and over
- Standard construction includes a galvanized casing and 6063-T5 anodized aluminum flow sensors
- Available in optional corrosive or high temperature resistance materials including Type 304L and 316L stainless steel, Hasteloy, Type 1 PVC, and phenolic and polyurethane enamel coatings
- Standard airflow stations can be operated (in air) continuously in temperatures up to 350°F or intermittently in temperatures up to 400°F
- All airflow stations can be operated in humidity ranges of 0 to 100%
- Standard airflow stations have good salt air resistance and are suitable for most HVAC applications

FE-1500 Technical Specifications

1. Accuracy

Within 2% of actual flow when installed in accordance with published recommendations

2. Operating Velocity Range

100 to 10,000 fpm

3. Material

Elements

6063-T5 anodized aluminum (standard)

Type 316L stainless steel (optional)

Hasteloy (optional)

Type 1 PVC (optional)

Casings

16 ga G90 galvanized steel (standard)

Type 304L stainless steel (optional)

Type 316L stainless steel (optional)

Hasteloy (optional)

Coatings

Heresite VRL 500 phenolic coating (optional)

Imron 333 polyurethane enamel (optional)

Note

Other corrosive resistant materials are available. Consult factory for further information.

4. Temperature

Galvanized Casings and Aluminum Elements

350°F continuous operation (in air)

400°F intermittent operation (in air)

Stainless Steel Casings and Elements

Type 304L-900°F continuous or intermittent operation (in air)

Type 316L-1600°F continuous or intermittent operation (in air)

Hastaloy Casings and Elements Elements

900°F continuous or intermittent operation (in air)

PVC Elements

120°F continuous operation and 170°F intermittent operation (in air)

Heresite Phenolic Coating

150°F continuous operation and 3200°F intermittent operation (in air)

Imron Polyurethane Enamel

200°F continuous operation and 300°F intermittent operation (in air)

Note

Corrosive resistant element maximum operating temperatures vary greatly with the concentration of the media in the process stream. Consult factory for further information.

5. Humidity

All Airflow Stations

0 to 100% non condensing

6. Corrosion Resistance

Galvanized Casings

Widely used for most air handling systems; not recommended for corrosive atmospheres

Aluminum Elements

Good salt, air, and mild acid gas resistance; excellent solvent and aromatic hydrocarbon resistance

Stainless Steel Elements and Casings

Good for sulfates, phosphates and other salts, as well as reducing acids such as sulphurous and phosphoric

Hastaloy Elements and Casings

Excellent resistance to strong oxidizers such as ferric and cupric chlorides, chlorine, formic and acetic acids, acetic anhydride, and salts.

PVC Elements

Excellent acid and alkalis resistance

Heresite Phenolic Coating

Excellent resistance to acids and salt air. Good resistance to alkalis and solvent.

Imron Polyurethane Enamel

Excellent resistance to acids, alkalis, salts, weather, and humidity. Very good resistance to solvents.

7. Instrument Connections

Aluminum Elements

¼" compression, suitable for use with thermoplastic or copper tubing; thermoplastic tubing requires the use of tubing inserts, which are supplied with the fittings

Stainless Steel and Hastaloy Elements

1/8-27 Female NPT

PVC Elements

1/8-27 Female NPT

FE-1500 Casing Construction

Circular Stations

Standard circular airflow measuring stations include a 16 gage galvanized casing with attached 90° connecting flanges as listed below:

Circular Flange Dimensions			
Station Size	Flange Thickness	Flange Size	Casing Length "L"
6" – 15"	0.064"	1"	6"
16" – 44"	0.064"	1½"	6"
45" – 72"	0.188"	1½"	10"
73" & Over	0.188"	2"	12"

Rectangular Stations

Standard rectangular airflow measuring stations include a 16 gage galvanized casing, 5 inches long, with formed integral 90° connecting flanges as listed below:

Rectangular Flange Dimensions	
Station Size	Flange Size
8" – 72"	1½"
73" & Over	2"

Oval Stations

Standard oval airflow measuring stations include a 18 gage galvanized casing, 5 inches long between beads with ¼ inch connecting sleeve on each end (7½ inch overall length). Actual O.D. dimensions are ¼ inch less than specified duct I.D. dimensions.

Oval Flange Dimensions (Optional)			
Station Width	Flange Thickness	Flange Size	Casing Length "L"
Up to 48"	0.064"	1½"	6"
Over 48"	0.188"	1½"	8"

FE-1500 Dimensions

Circular Stations

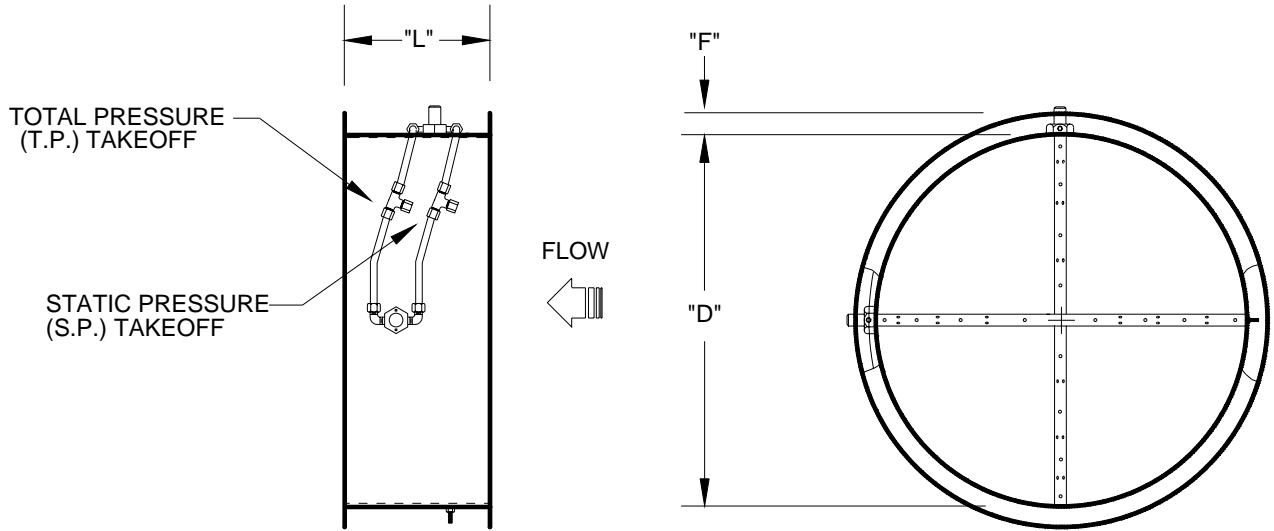

Rectangular Stations

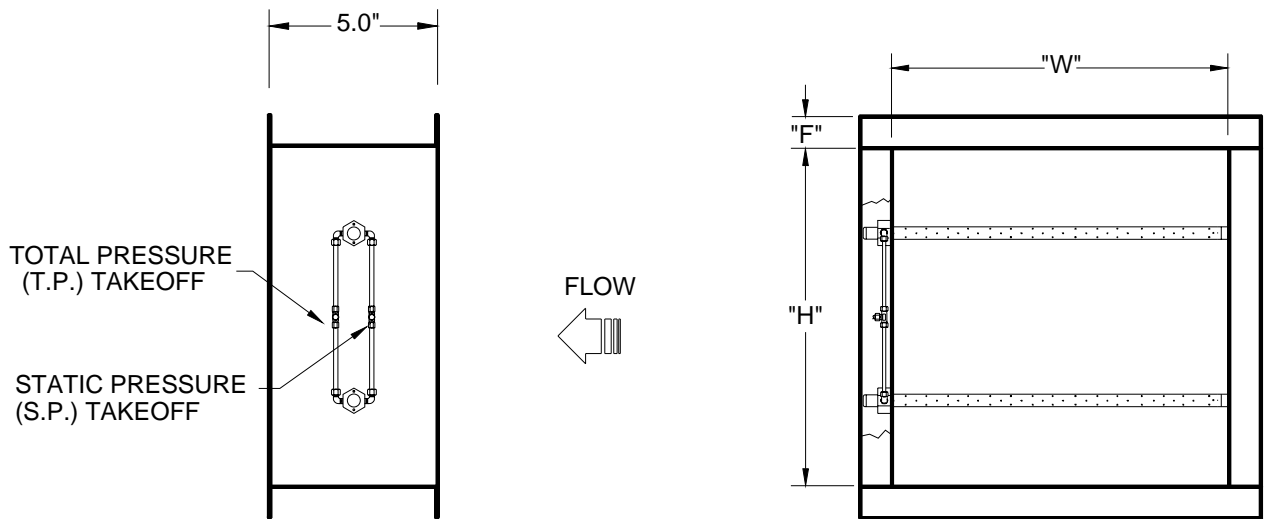

FE-1500 Dimensions (Continued)

Oval Stations

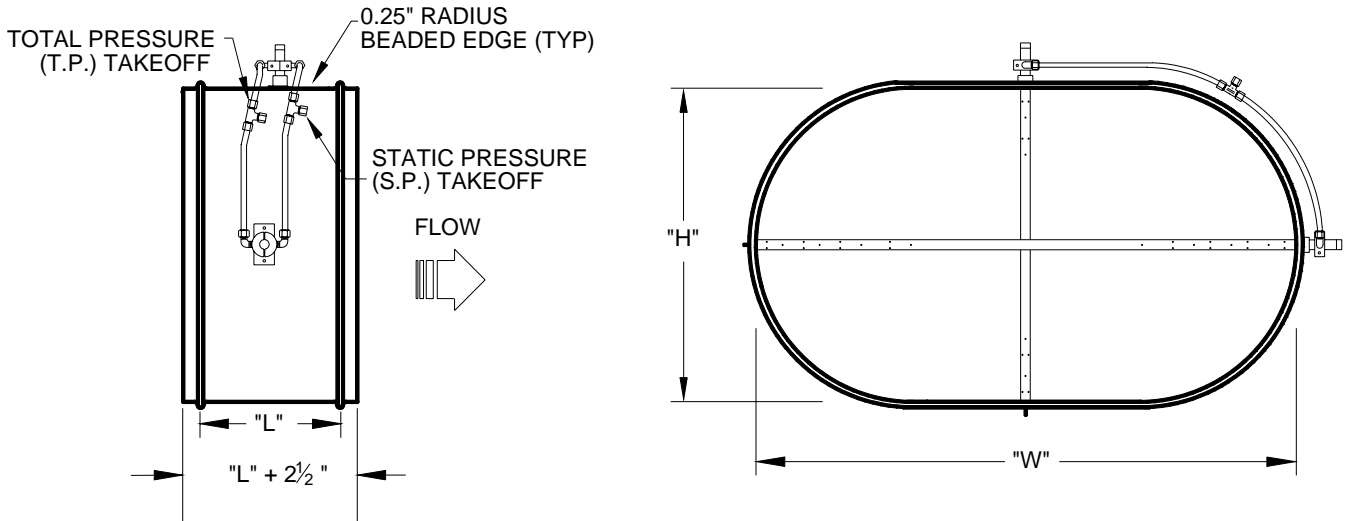

FE-1500 Minimum Installation requirements

The elements may be installed in any duct configuration. However, the accuracy of the installation is dependent on the flow conditions in the duct. The minimum installation requirements for the elements based upon a uniform velocity profile approaching the duct disturbance for flow rates less than 2,500 fpm are shown below. Add one duct diameter to the installation requirements shown below for each additional flow rate of 1,000 fpm. These are not ideal locations. It is always best to locate the elements as far as possible from all duct disturbances, with upstream disturbances being the most critical consideration.

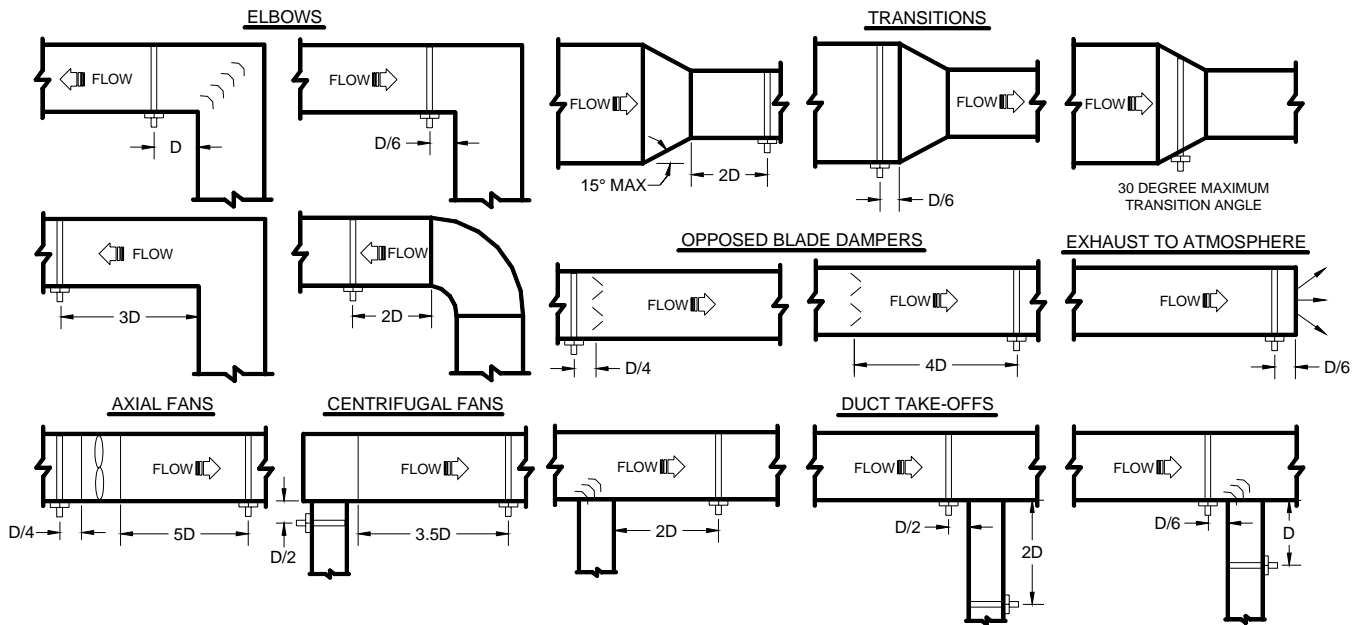

Notes:

Round Ducts:

D = Duct diameter

Rectangular Ducts:

$$D = \sqrt{\frac{4HW}{\pi}}$$

H = Duct height

W = Duct width

FE-1500 Resistance to Airflow

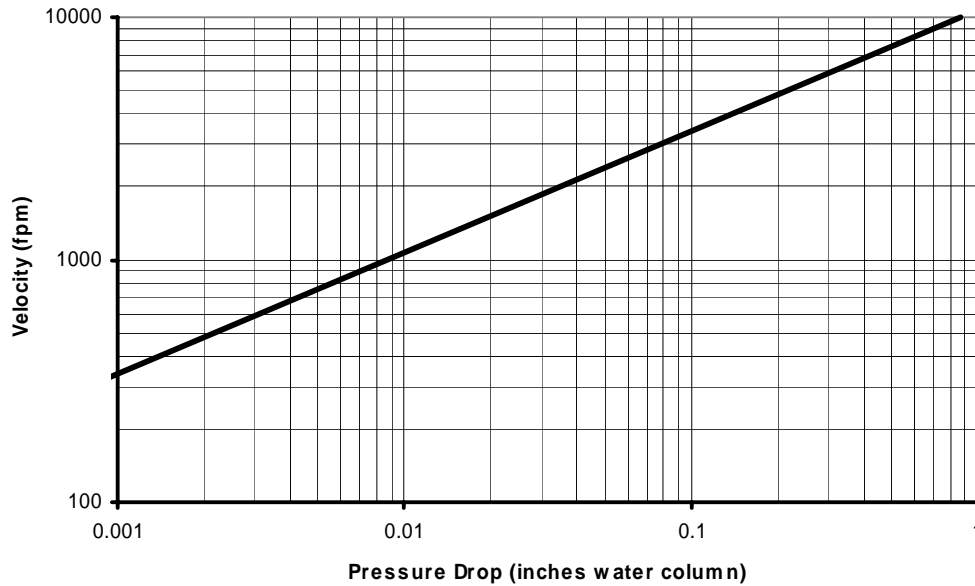

FE-1500 Ordering Information

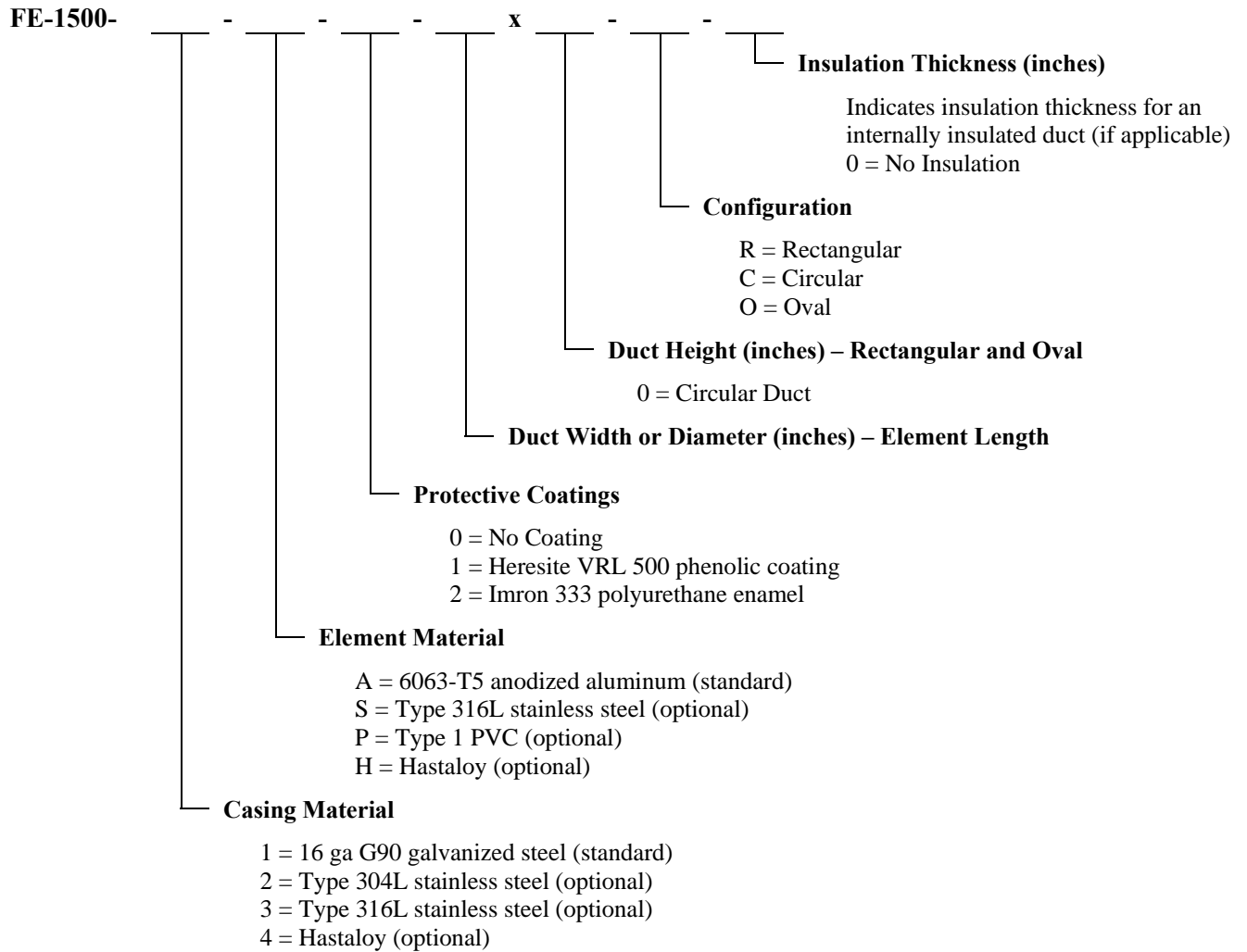

FE-1500 Specification Guide

Airflow Measurement Stations

1. Provide where indicated and/or scheduled airflow traverse elements capable of continuously monitoring the fan or duct air volumes they serve.
2. Each element shall be designed and built to comply with, and provide results in accordance with, accepted practice for duct system traversing as defined in the ASHRAE Handbook of Fundamentals, AMCA publication #203, as well as the Industrial Ventilation Handbook. The number of sensing ports on each element, and the quantity of elements utilized at each installation, shall comply with ASHRAE Standard #111 for equal area duct traversing.
3. Each airflow measuring element shall contain multiple total and static pressure sensing ports placed along the leading edge of the cylinder. The static pressure chamber shall incorporate dual offset static taps on opposing sides of the averaging chamber, so as to be insensitive to flow angle variations of as much as ± 20 degrees in the approaching airstream.
4. The airflow traverse elements shall be capable of producing steady, non-pulsating signals of true total and static pressure, with an accuracy of 2% of actual flow for operating velocities as low as 100 feet per minute (fpm). Signal amplifying sensors requiring flow correction (K factors) for field calibration are not acceptable.
5. The airflow traverse elements shall not induce a measurable pressure drop, greater than 0.18 inch at 4,000 fpm. The units shall have a self-generated sound rating of less than NC40 and the sound level within the duct shall not be amplified, nor shall additional sound be generated.
6. The probes shall be manifolded together in a 16 gauge galvanized steel duct section with 90 degree undrilled flanges, fabricated to the duct size, and shall contain multiple airflow traverse elements interconnected as herein before described.
7. Where primary flow elements are located outside of the manufacturer's published installation guidelines the manufacturer shall be consulted, and approve of any special configurations, such as air equalizers and/or additional and strategically placed measuring points, as may be required.
8. Where the stations are installed in insulated ducts, the airflow passage of the station shall be the same size as the inside airflow dimension of the duct. Station flanges shall be sized to facilitate matching connecting ductwork.

Installation Considerations

1. Primary flow elements shall be installed in strict accordance with the manufacture's published requirements and with ASME guidelines effecting non-standard approach conditions. These elements serve as the primary signals for the airflow systems; it shall be the responsibility of the contractor to verify correct installation to assure that accurate primary signals are obtained.
2. An identification label shall be placed on each unit casing listing model number, size, area, and specified airflow capacity.

Manufacturer

1. Airflow measurement stations shall be Paragon Controls Inc. Model FE-1500 or equal as approved by the Engineer.
2. Naming of a manufacturer does not automatically constitute acceptance of this standard product nor waive the responsibility of the manufacturer to comply totally with all requirements of the proceeding specification.

Engineering Reference Table

VELOCITY VERSUS VELOCITY PRESSURE											
V = VELOCITY IN FEET PER MINUTE						P _v = VELOCITY PRESSURE IN INCHES H ₂ O					
V	P _v	V	P _v	V	P _v	V	P _v	V	P _v	V	P _v
180	0.0020	620	0.0240	1060	0.0701	1500	0.1403	1940	0.2346	2760	0.4749
190	0.0023	630	0.0247	1070	0.0714	1510	0.1422	1950	0.2371	2780	0.4818
200	0.0025	640	0.0255	1080	0.0727	1520	0.1440	1960	0.2395	2800	0.4888
210	0.0027	650	0.0263	1090	0.0741	1530	0.1459	1970	0.2420	2820	0.4958
220	0.0030	660	0.0272	1100	0.0754	1540	0.1479	1980	0.2444	2840	0.5028
230	0.0033	670	0.0280	1110	0.0768	1550	0.1498	1990	0.2469	2860	0.5099
240	0.0036	680	0.0288	1120	0.0782	1560	0.1517	2000	0.2494	2880	0.5171
250	0.0039	690	0.0297	1130	0.0796	1570	0.1537	2020	0.2544	2900	0.5243
260	0.0042	700	0.0305	1140	0.0810	1580	0.1556	2040	0.2595	2920	0.5316
270	0.0045	710	0.0314	1150	0.0825	1590	0.1576	2060	0.2646	2940	0.5389
280	0.0049	720	0.0323	1160	0.0839	1600	0.1596	2080	0.2697	2960	0.5462
290	0.0052	730	0.0332	1170	0.0853	1610	0.1616	2100	0.2749	2980	0.5536
300	0.0056	740	0.0341	1180	0.0868	1620	0.1636	2120	0.2802	3000	0.5611
310	0.0060	750	0.0351	1190	0.0883	1630	0.1656	2140	0.2855	3020	0.5686
320	0.0064	760	0.0360	1200	0.0898	1640	0.1677	2160	0.2909	3040	0.5762
330	0.0068	770	0.0370	1210	0.0913	1650	0.1697	2180	0.2963	3060	0.5838
340	0.0072	780	0.0379	1220	0.0928	1660	0.1718	2200	0.3017	3080	0.5914
350	0.0076	790	0.0389	1230	0.0943	1670	0.1739	2220	0.3073	3100	0.5991
360	0.0081	800	0.0399	1240	0.0959	1680	0.1760	2240	0.3128	3120	0.6069
370	0.0085	810	0.0409	1250	0.0974	1690	0.1781	2260	0.3184	3140	0.6147
380	0.0090	820	0.0419	1260	0.0990	1700	0.1802	2280	0.3241	3160	0.6225
390	0.0095	830	0.0429	1270	0.1006	1710	0.1823	2300	0.3298	3180	0.6304
400	0.0100	840	0.0440	1280	0.1021	1720	0.1844	2320	0.3356	3200	0.6384
410	0.0105	850	0.0450	1290	0.1037	1730	0.1866	2340	0.3414	3220	0.6464
420	0.0110	860	0.0461	1300	0.1054	1740	0.1888	2360	0.3472	3240	0.6545
430	0.0115	870	0.0472	1310	0.1070	1750	0.1909	2380	0.3531	3260	0.6626
440	0.0121	880	0.0483	1320	0.1086	1760	0.1931	2400	0.3591	3280	0.6707
450	0.0126	890	0.0494	1330	0.1103	1770	0.1953	2420	0.3651	3300	0.6789
460	0.0132	900	0.0505	1340	0.1119	1780	0.1975	2440	0.3712	3320	0.6872
470	0.0138	910	0.0516	1350	0.1136	1790	0.1998	2460	0.3773	3340	0.6955
480	0.0144	920	0.0528	1360	0.1153	1800	0.2020	2480	0.3834	3360	0.7038
490	0.0150	930	0.0539	1370	0.1170	1810	0.2042	2500	0.3897	3380	0.7122
500	0.0156	940	0.0551	1380	0.1187	1820	0.2065	2520	0.3959	3400	0.7207
510	0.0162	950	0.0563	1390	0.1205	1830	0.2088	2540	0.4022	3420	0.7292
520	0.0169	960	0.0575	1400	0.1222	1840	0.2111	2560	0.4086	3440	0.7378
530	0.0175	970	0.0587	1410	0.1239	1850	0.2134	2580	0.4150	3460	0.7464
540	0.0182	980	0.0599	1420	0.1257	1860	0.2157	2600	0.4214	3480	0.7550
550	0.0189	990	0.0611	1430	0.1275	1870	0.2180	2620	0.4280	3500	0.7637
560	0.0196	1000	0.0623	1440	0.1293	1880	0.2203	2640	0.4345	3520	0.7725
570	0.0203	1010	0.0636	1450	0.1311	1890	0.2227	2660	0.4411	3540	0.7813
580	0.0210	1020	0.0649	1460	0.1329	1900	0.2251	2680	0.4478	3560	0.7901
590	0.0217	1030	0.0661	1470	0.1347	1910	0.2274	2700	0.4545	3580	0.7990
600	0.0224	1040	0.0674	1480	0.1366	1920	0.2298	2720	0.4612	3600	0.8080
610	0.0232	1050	0.0687	1490	0.1384	1930	0.2322	2740	0.4681	3620	0.8170
										3640	0.8260
										3660	0.8351
										3680	0.8443
										3700	0.8535
										3720	0.8627
										3740	0.8720
										3760	0.8814
										3780	0.8908
										3800	0.9002
										3820	0.9097
										3840	0.9193
										3860	0.9289
										3880	0.9386
										3900	0.9483
										3920	0.9580
										3940	0.9678
										3960	0.9777
										3980	0.9876
										4000	0.9975
										4050	1.0226
										4100	1.0480
										4150	1.0737
										4200	1.0997
										4250	1.1261
										4300	1.1527
										4350	1.1797
										4400	1.2070
										4450	1.2346
										4500	1.2625
										4550	1.2907
										4600	1.3192
										4650	1.3480
										4700	1.3772
										4750	1.4066
										4800	1.4364
										4850	1.4665
										4900	1.4969
										4950	1.5276
										5000	1.5586
										5050	1.5899
										5100	1.6216
										5150	1.6535
										5200	1.6858
										5250	1.7184
										5300	1.7512
										5350	1.7844
										5400	1.8180
										5450	1.8518
										5500	1.8859
										5550	1.9204
										5600	1.9551
										5650	1.9902
										5700	2.0256
										5750	2.0613
										5800	2.0973
										5850	2.1336
										5900	2.1702
										5950	2.2071
										6000	2.2444
										6050	2.2819
										6100	2.3198
										6150	2.3580
										6200	2.3965
										6250	2.4353
										6300	2.4744
										6350	2.5139
										6400	2.5536
										6450	2.5937
										6500	2.6340
										6550	2.6747
										6600	2.7157
										6650	2.7570
										6700	2.7986
										6750	2.8406
										6800	2.8828
										6850	2.9253
										6900	2.9682
										7000	3.0549
										7100	3.1428
										7200	3.2319
										7300	3.3223
										7400	3.4140
										7500	3.5069
										7600	3.6010
										7700	3.6964
										7800	3.7930
										7900	3.8909
										8000	3.9900

Above P_v Values Are Based On Standard Air Density Of 0.075 lbm/ft³ Which Is Air At 68°F, 50% Relative Humidity, And 29.92" Hg. The equation for converting air volume (Q) into velocity (V) and velocity pressure (P_v) is:

$$V = \frac{Q}{A}$$

$$P_v = \left(\frac{V}{C}\right)^2 \times \rho$$

Where:

V = Velocity, in fpm

Q = Flow, in cfm

A = Area, in ft²

C = 1096.7

ρ = Density of air, in lb/ft³

P_v = Velocity pressure, in inches H₂O